

Jøtul F 273 / F 363 / F 373 / F 473

Tilleggsutstyr/Optional equipment

NO/DK	- Monteringsanvisning	3
SE	- Monteringsanvisning	3
FI	- Asennus- ja käyttöohje	3
GB	- Installation Instructions	3
FR	- Manuel d'installation	3
ES	- Instrucciones para instalación	3
IT	- Manuale di installazione	3
DE	- Montageanleitung	3
NL	- Installatiehandleiding	3

Dreiesett / Rotation set

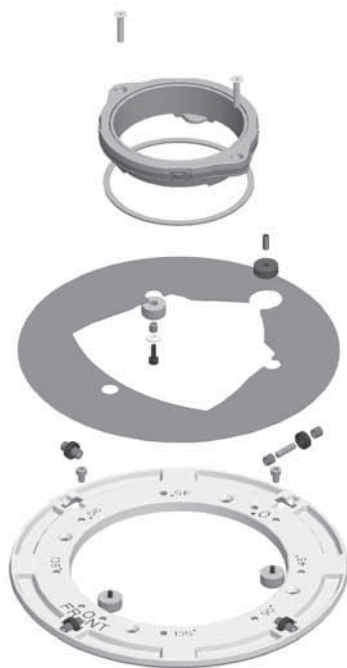

Cat.no.: 350997



Monterings- og bruksanvisningen må oppbevares under hele produktets levetid. These instructions must be kept for future references. Wir empfehlen Ihnen, die Montage- und Bedienungsanleitung für spätere Zwecke sorgfältig aufzubewahren. Ce document doit être conservé pendant toute la vie de l'appareil.

Jøtul F 273 / F 363 / F 373 / F 473

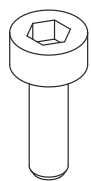

X 3
117731 - M6x20mm



X 3
120004 - $\varnothing 6,4 \times \varnothing 18 \times 1,6$ mm



X 3
128934 - $\varnothing 10 \times \varnothing 6,2 \times 10$ mm

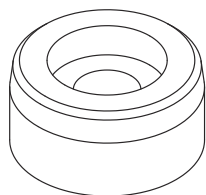

X 3
221870 - $\varnothing 30 \times 15$ mm



X 1
118141 - M8x20mm

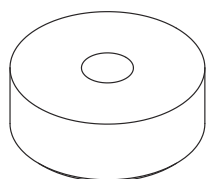

X 1
221871 - $\varnothing 30 \times 11,5$ mm

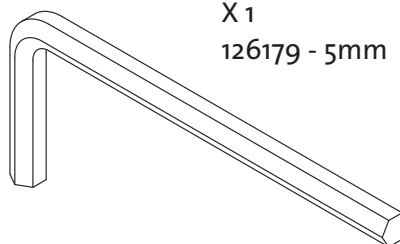

X 1
126179 - 5mm

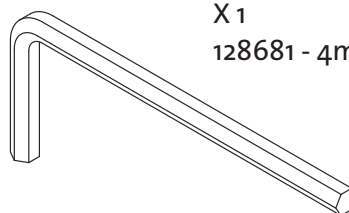

X 1
128681 - 4mm

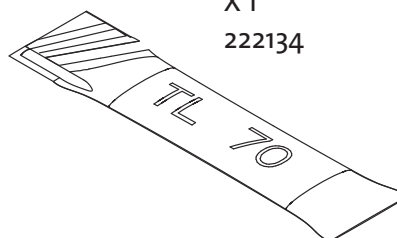

X 1
222134

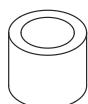

X 8
128112
 $\varnothing 12 \times \varnothing 8,2 \times 10$ mm



X 4
221872
6082Z $\varnothing 22 \times \varnothing 8 \times 7$ mm



X 4
118142
M8x30mm

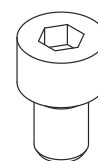

X 2
117749
M8x12mm

Jøtul F 273 / F 363 / F 373 / F 473

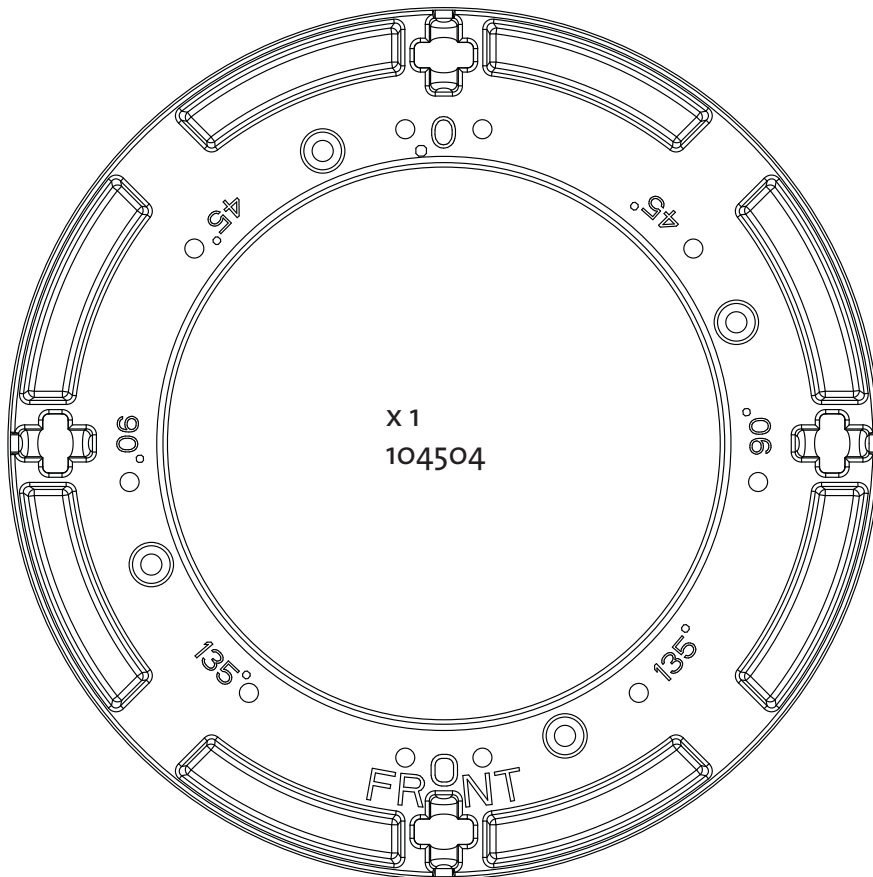
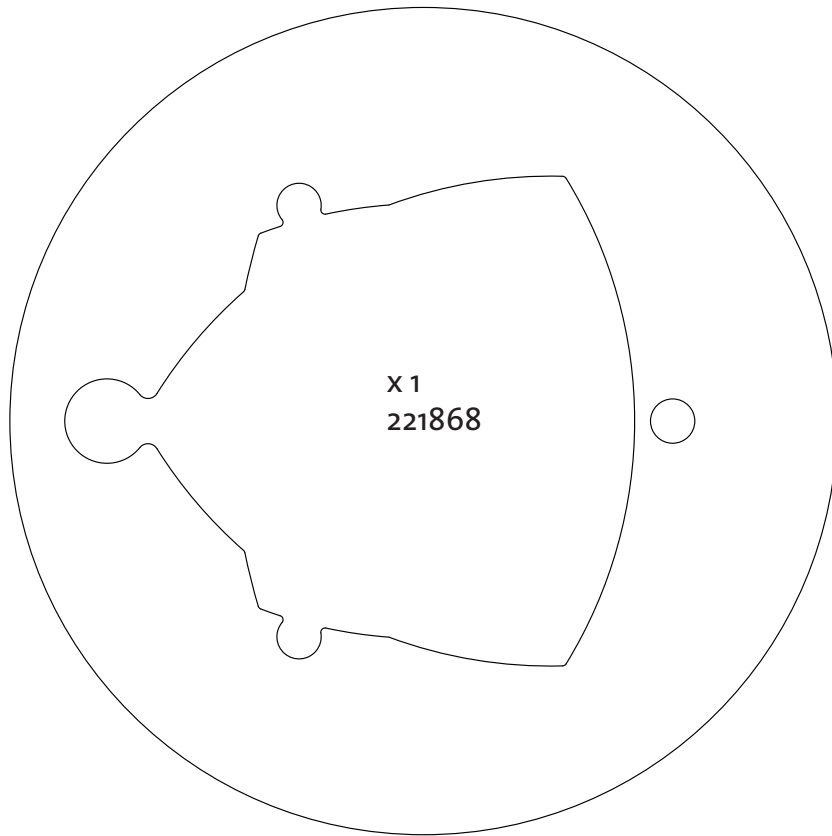

Jøtul F 273

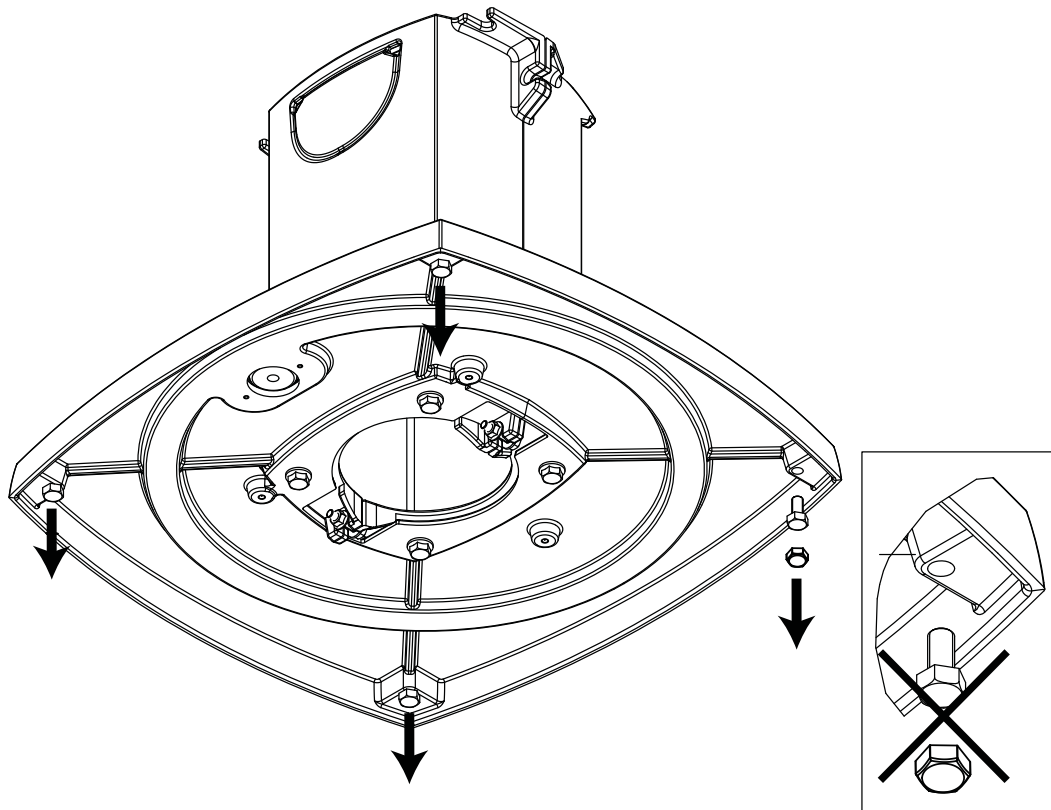

Jøtul F 363 / F 373

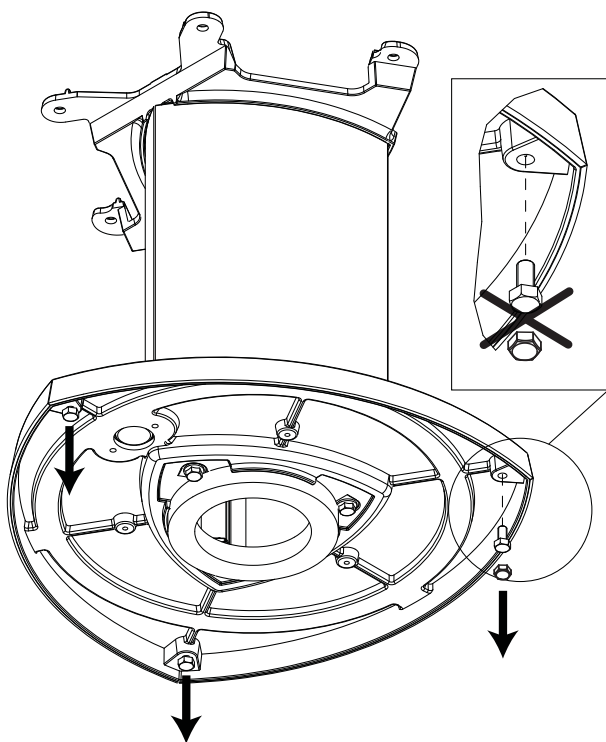

Jøtul F 473

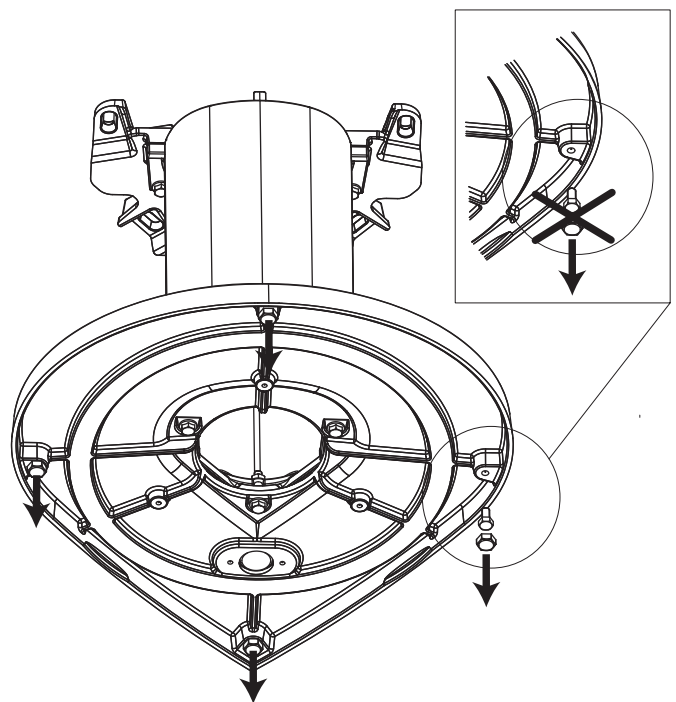

Jøtul F 273

1

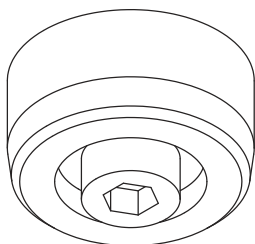
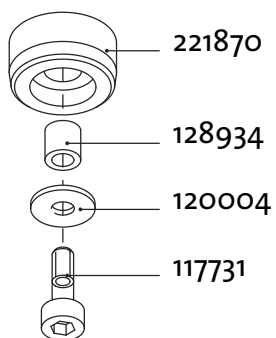

2

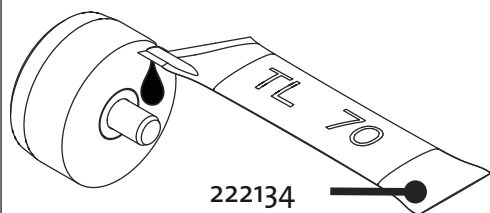

3

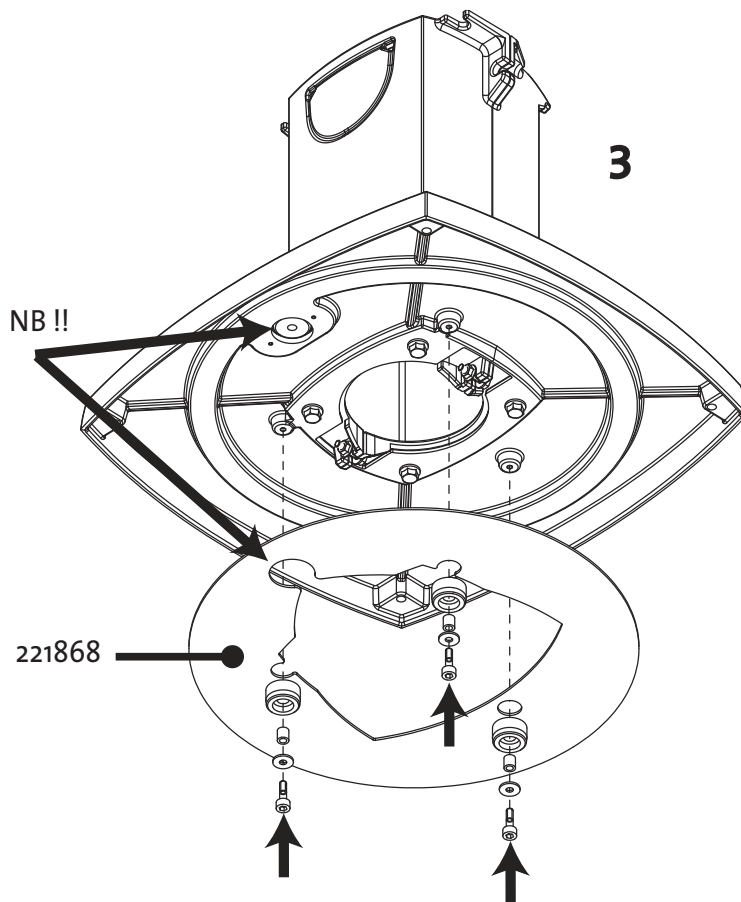

4

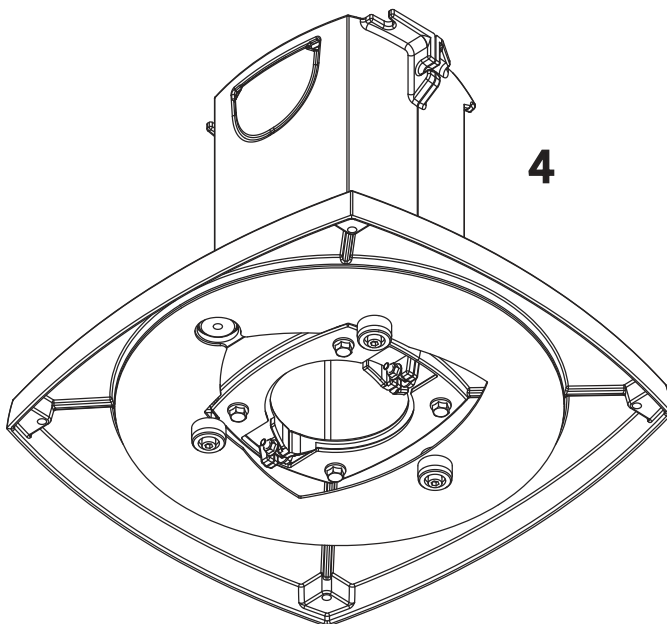

Jøtul F 363 / F 373

1

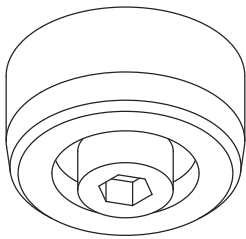
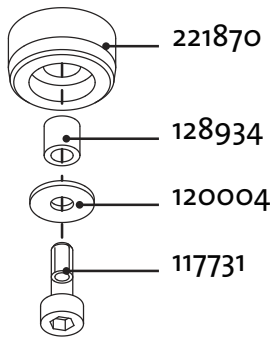

2

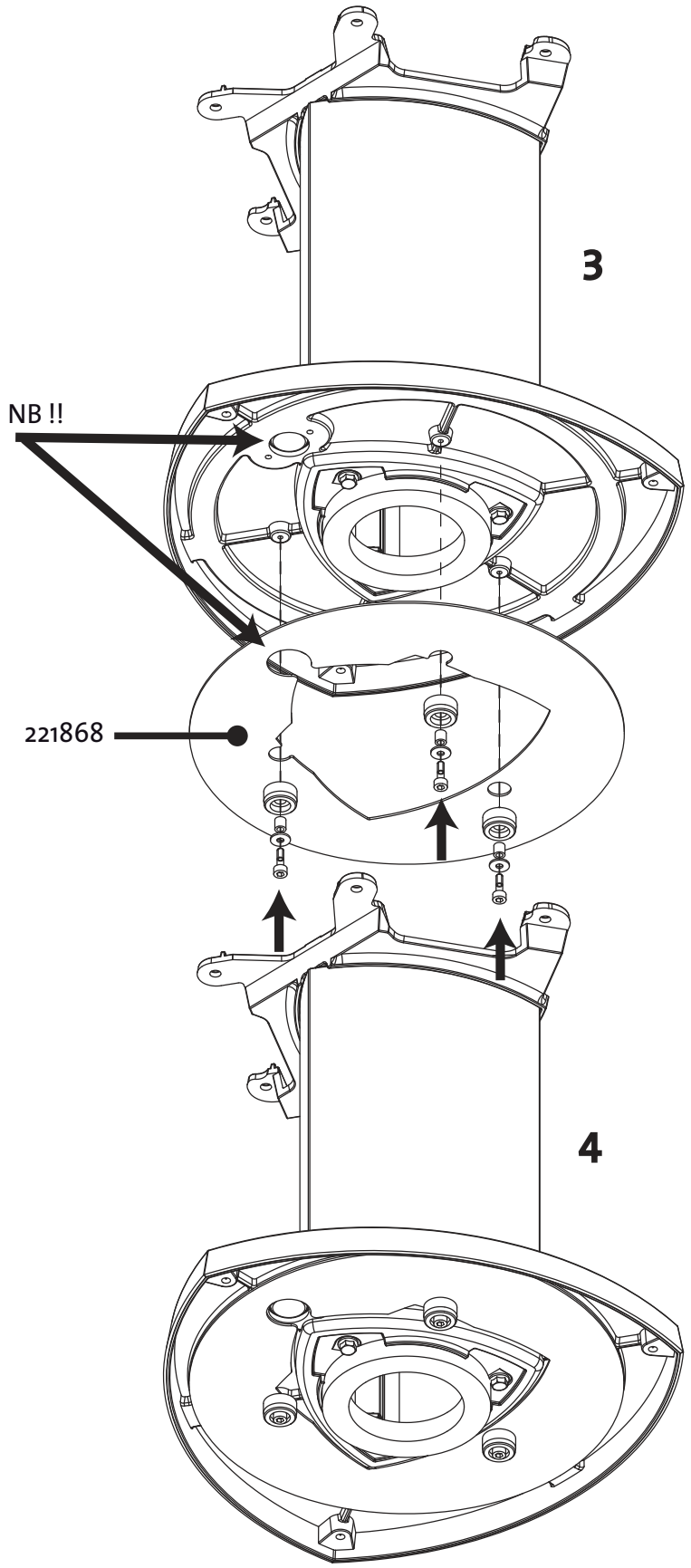
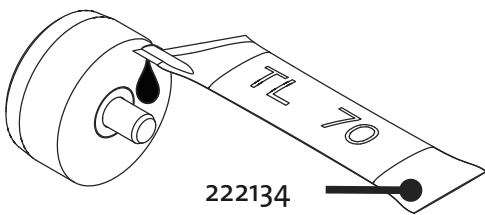

Jøtul F 473

1

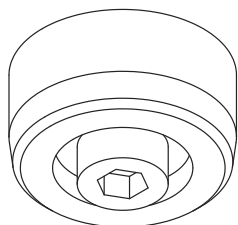
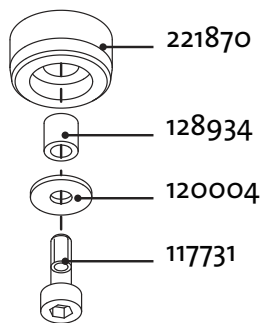

2

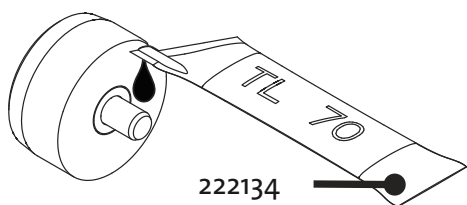

3

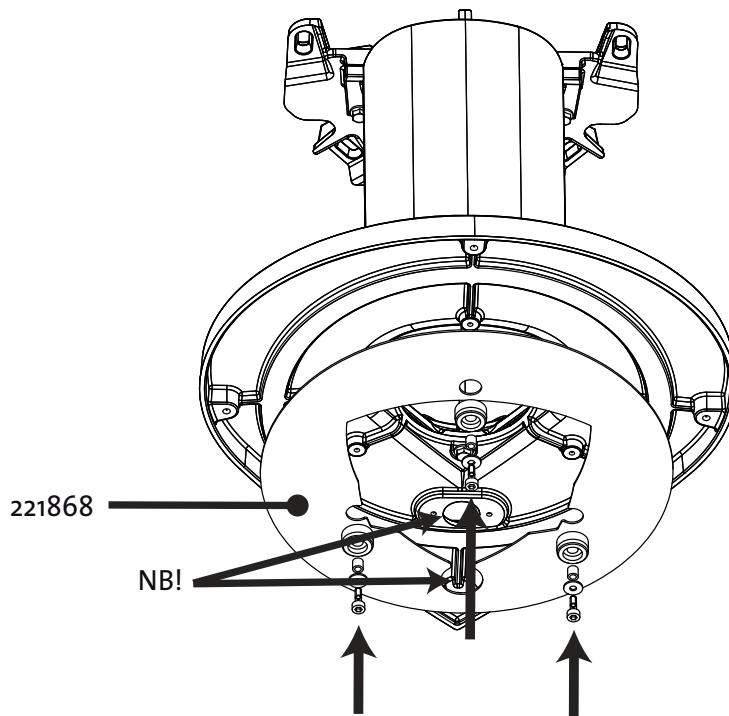

4

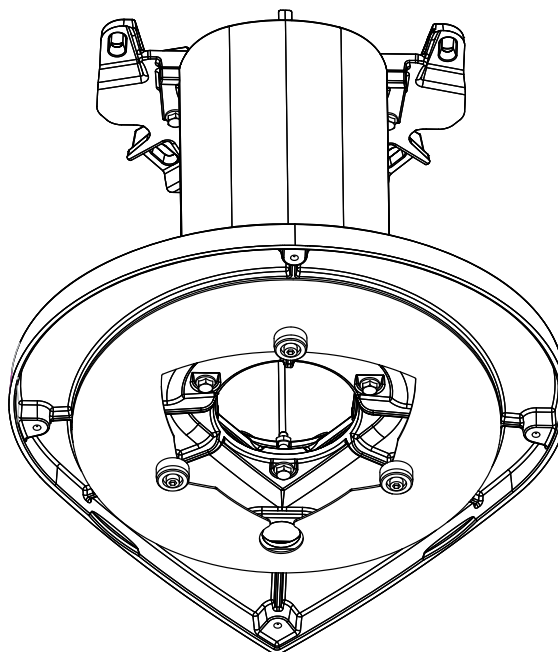

Jøtul F 273 / F 363 / F 373 / F 473

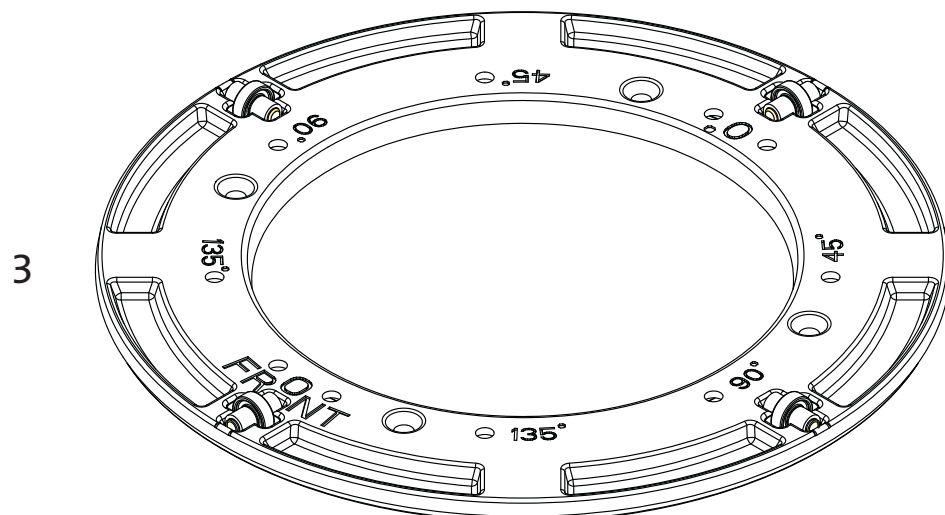
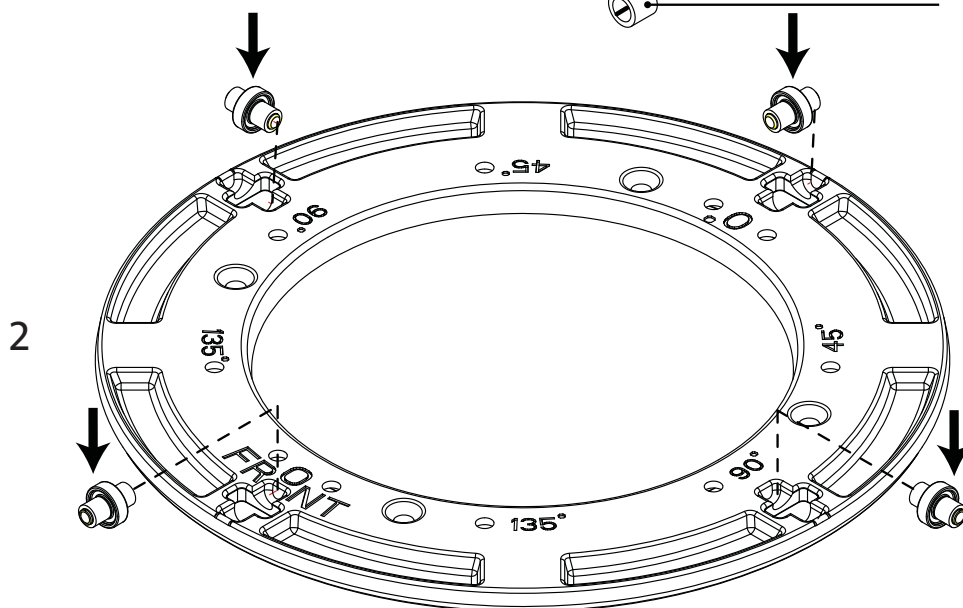
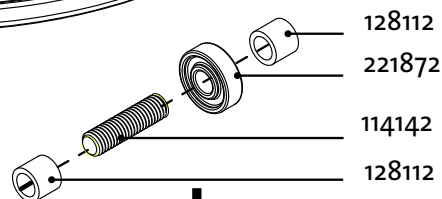
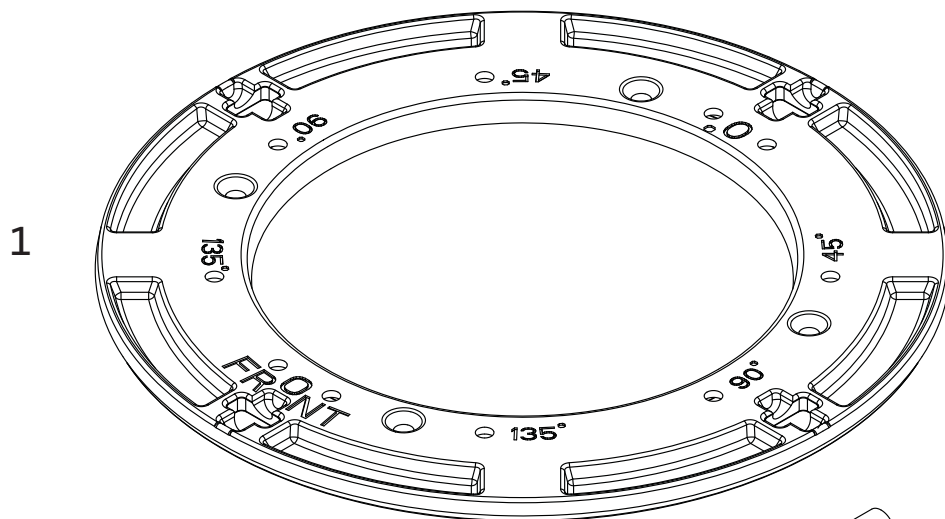

Jøtul F 273 / F 363 / F 373 / F 473

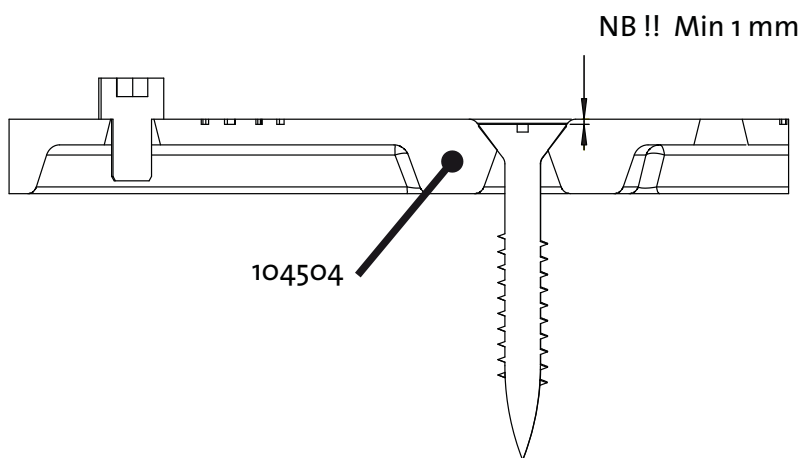
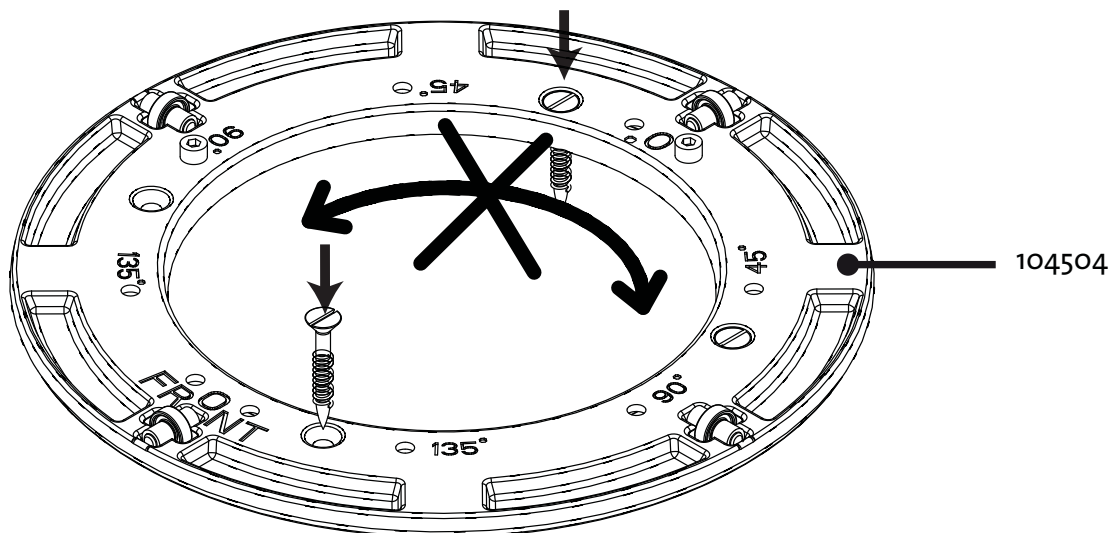

NO/DK: Ring 104504 må festes til gulv med skruer, dobbeltsidig tape eller lim (følger ikke med).

SE: Ring 104504 måste fästas till golvet med skruvar, dubbelsidig tape eller limm (medföljer ei).

GB: Ring 104504 must be fastened to floor with screws, double sided tape or glue (not supplied).

FR: L'anneau 104504 doit être fixé au sol par des vis ou du ruban autocollant double face ou de la colle (non fournis).

ES: El anillo 104504 debe ser sujeto al suelo con tornillos, cinta de doble cara o pegamento (no suministrado).

IT: L'anello 104504 deve essere fissato al pavimento con: Delle viti, del nastro bio-adesivo o della colla (non inclusi nella confezione).

DE: Ring 104504 muss auf dem Boden mit Schrauben, zweiseitige Klebestreifen oder Leim befestigt werden (nicht mitgeliefert).

NL: Ring 104504 moet aan de vloer worden vastgemaakt met schroeven, dubbelzijdig tape of lijm (niet meegeleverd).

Jøtul F 273 / F 363 / F 373 / F 473

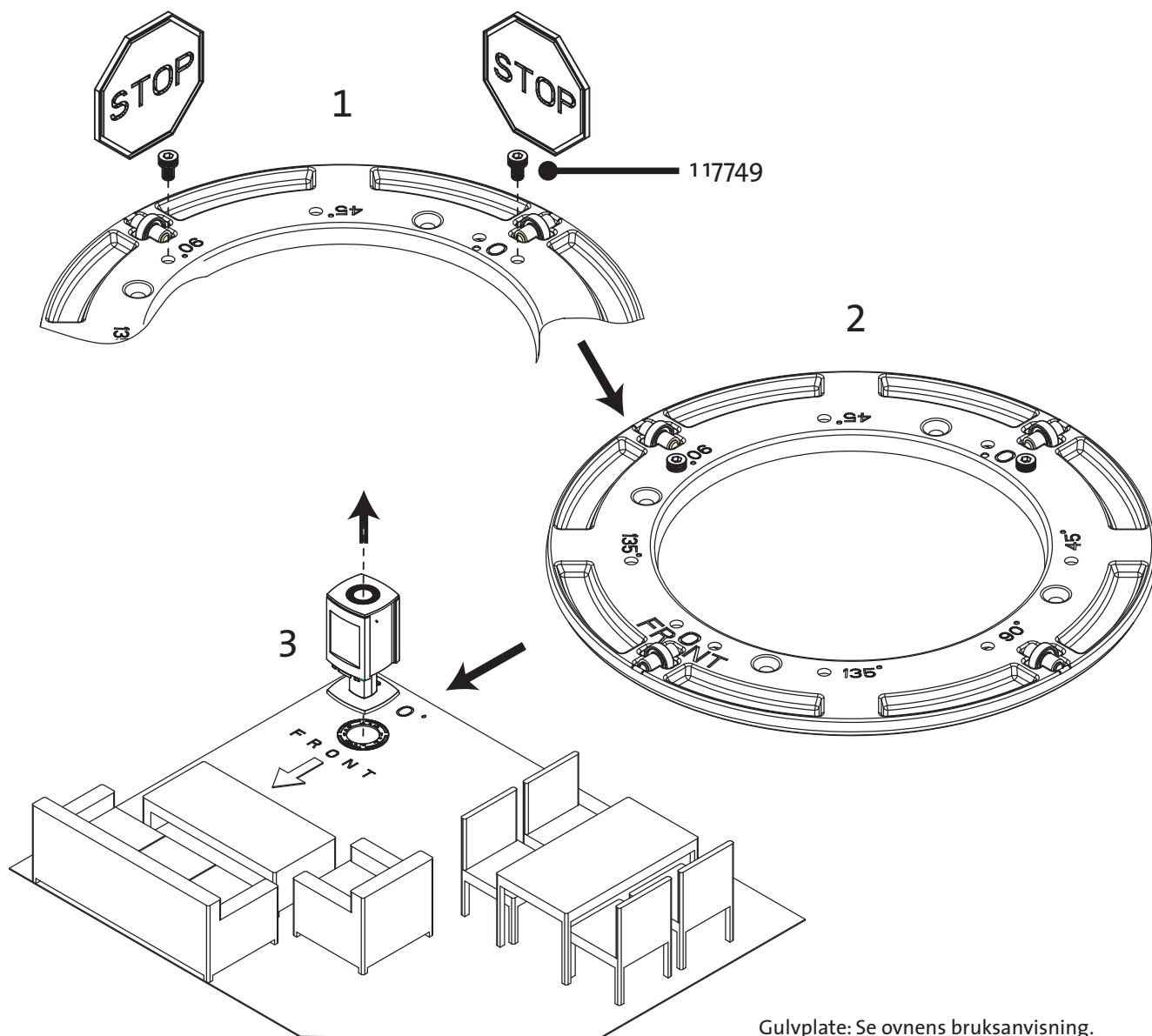

Gulvplate: Se ovns bruksanvisning.
Floor plate: See stove manual.

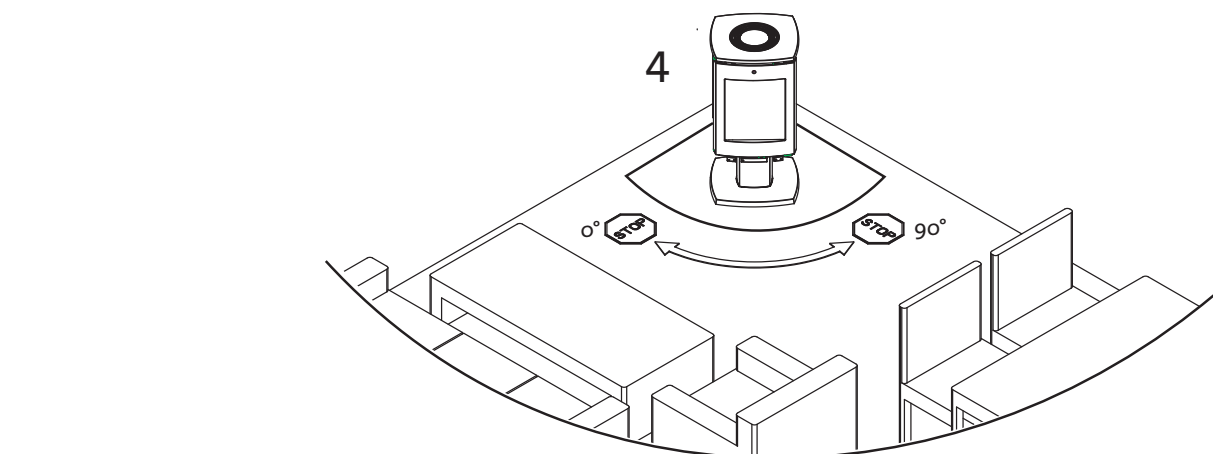

Jøtul F 273

1

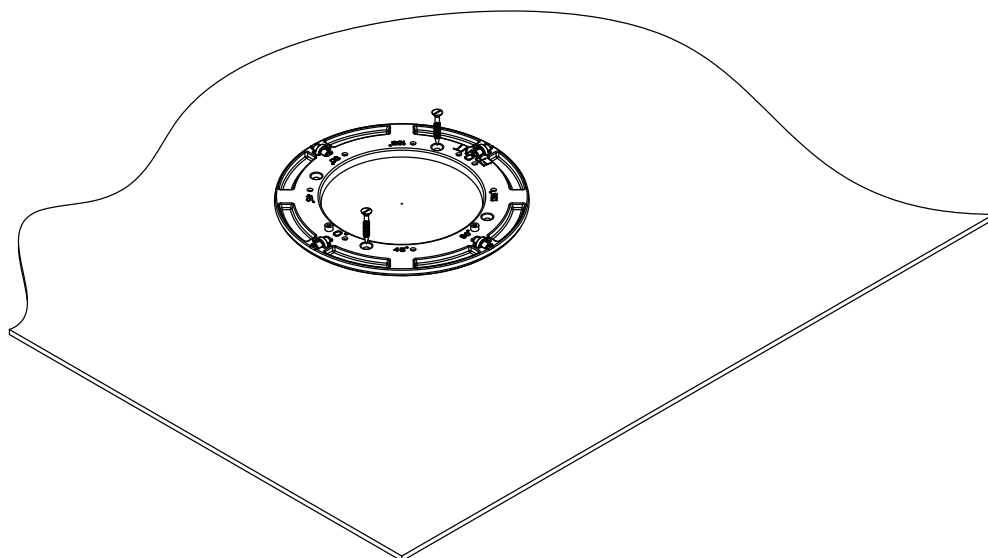

2

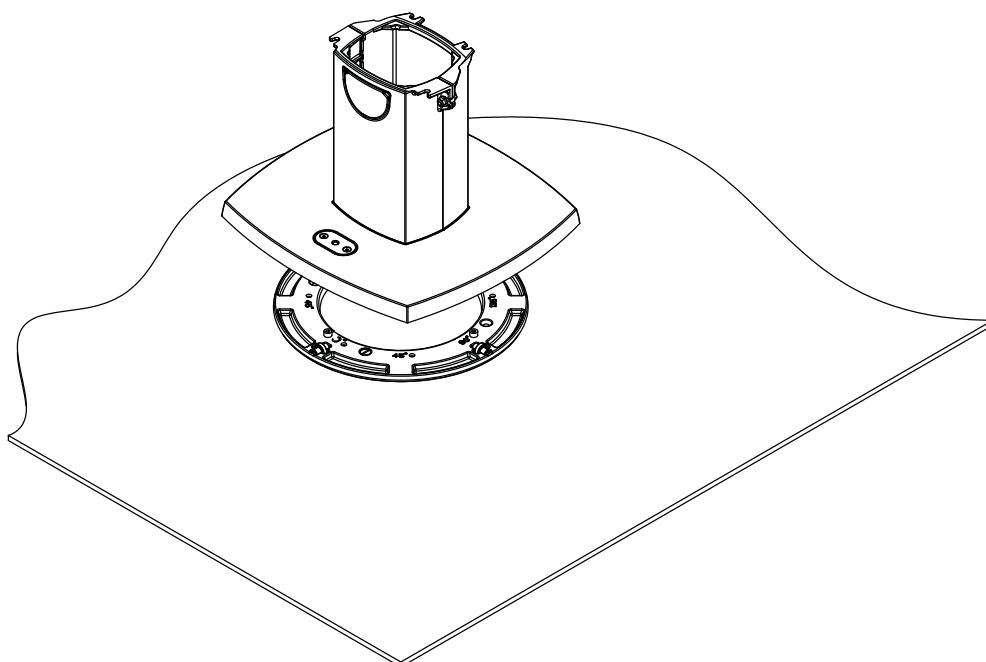

3

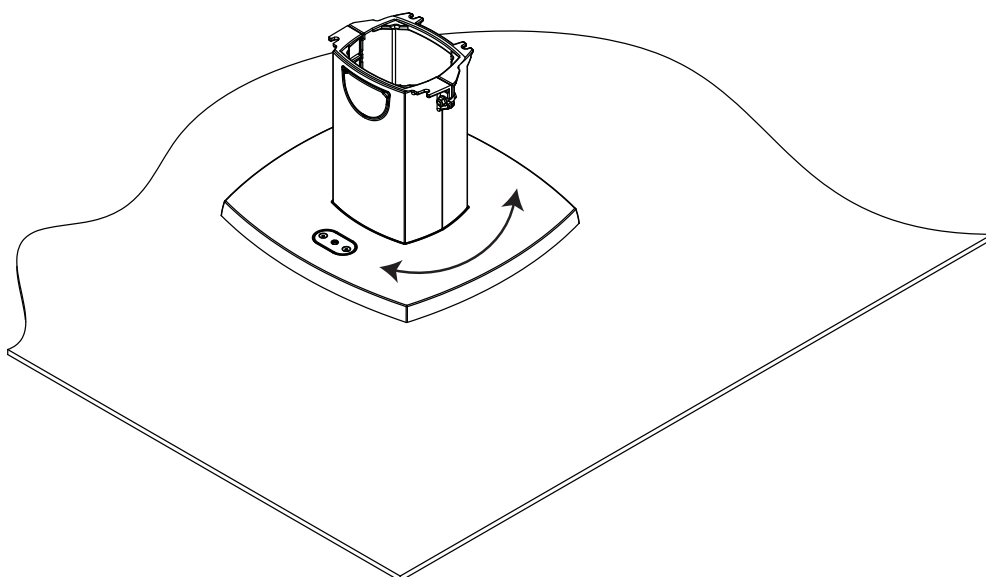

Jøtul F 273

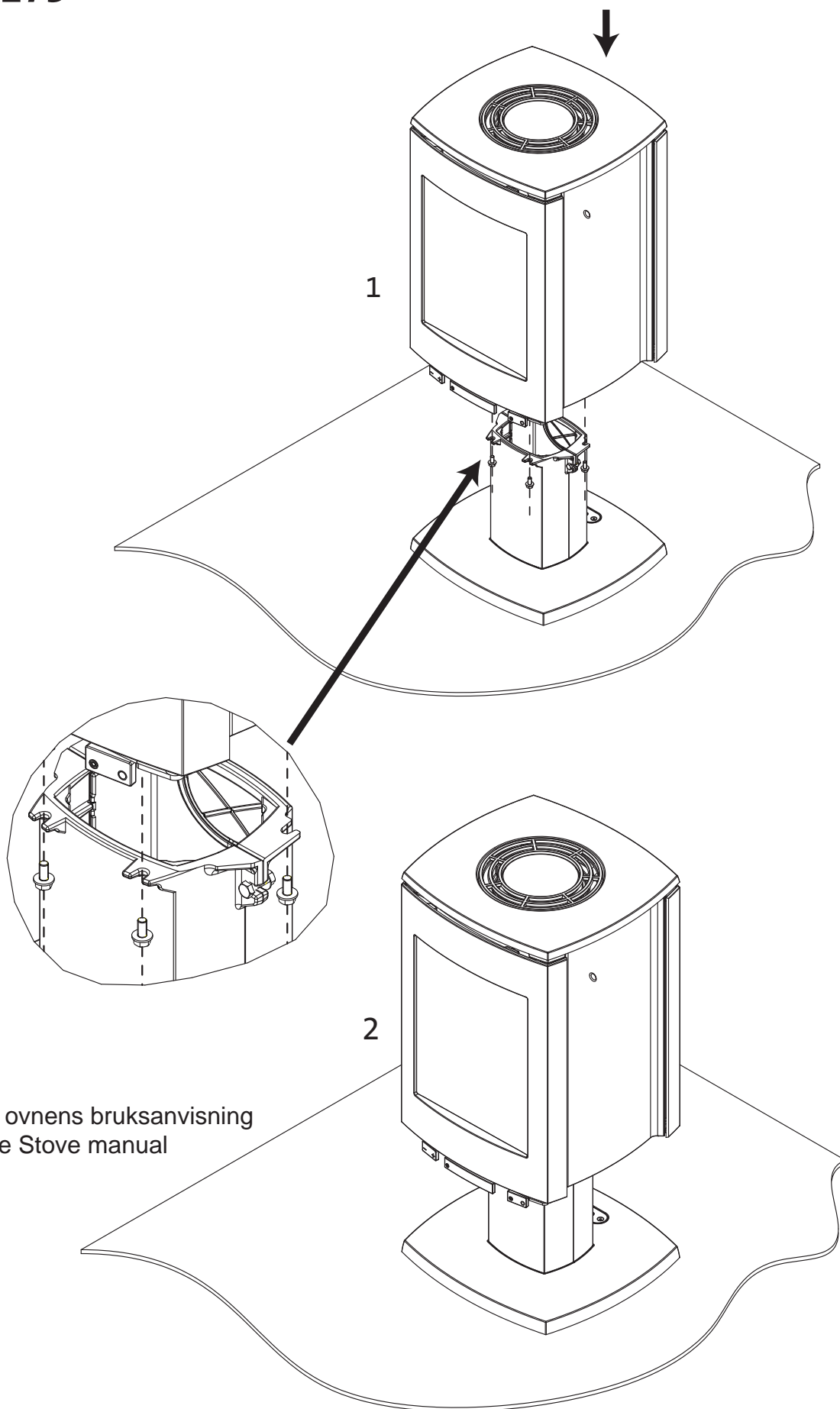

Jøtul F 273

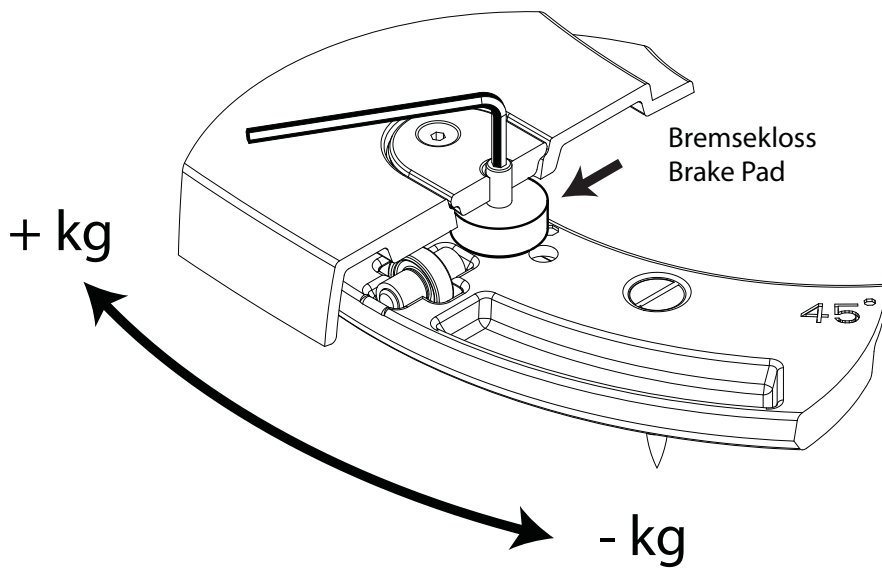
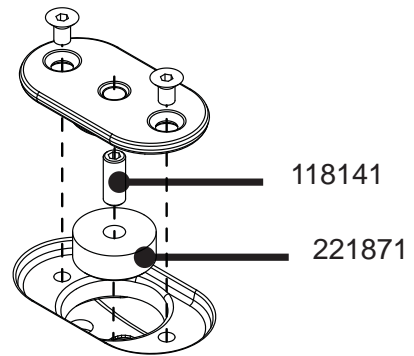
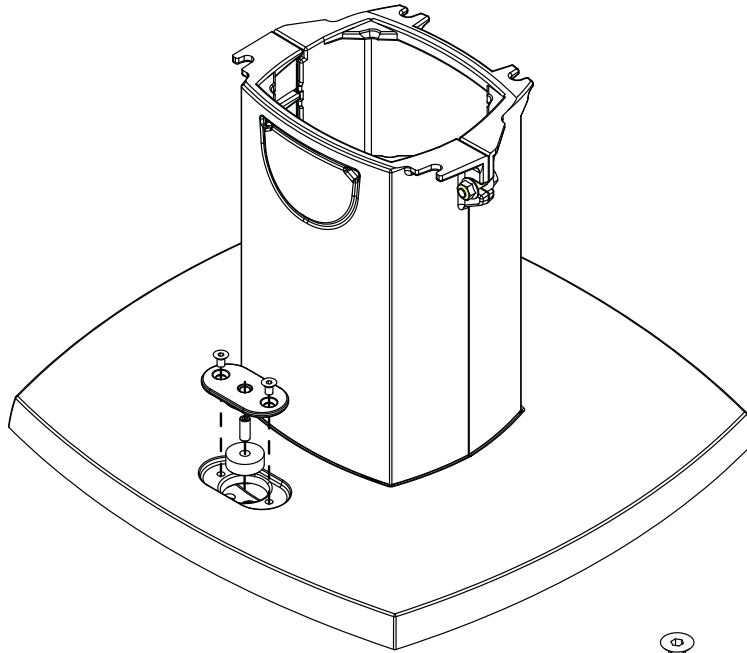

Jøtul F 363 / F 373 / F 473

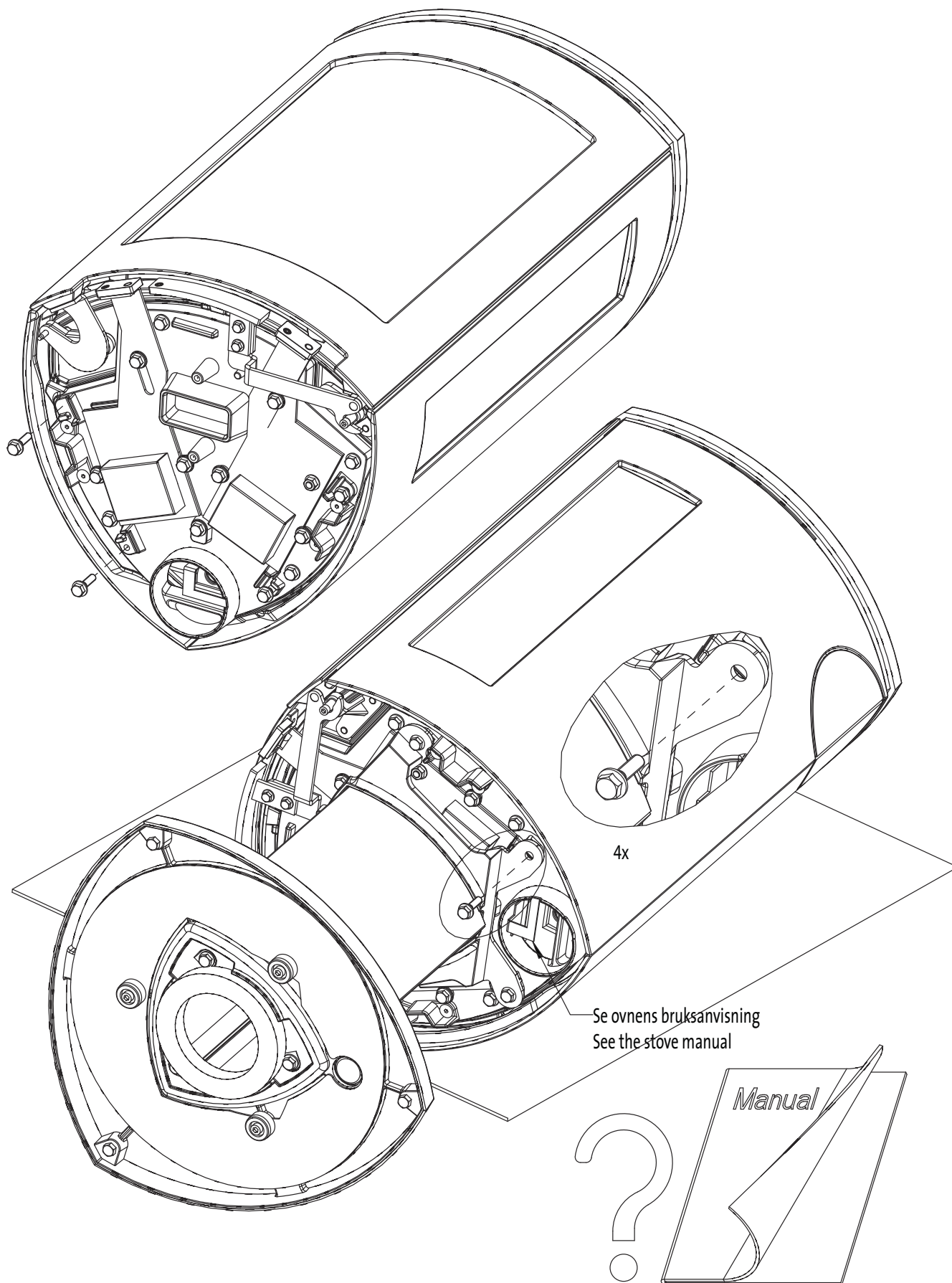

Jøtul F 363 / F 373 / F 473

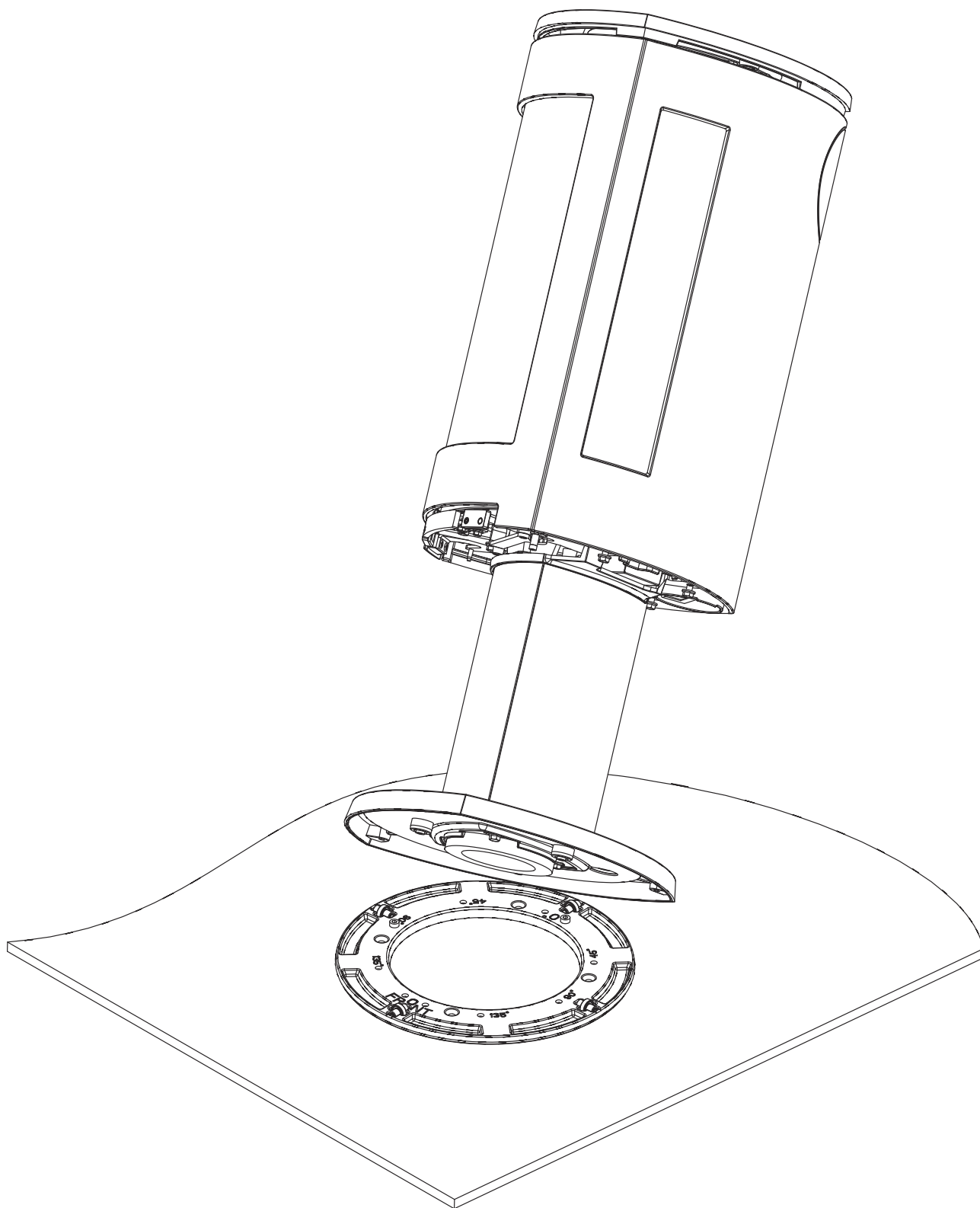

Jøtul F 363 / F 373 / F 473

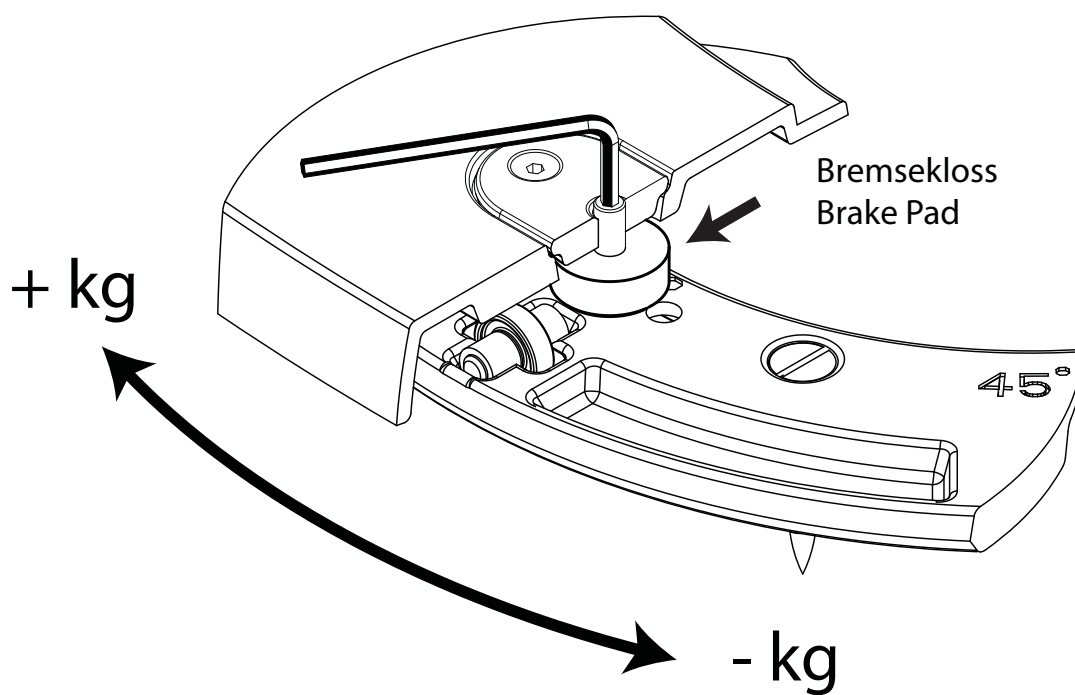
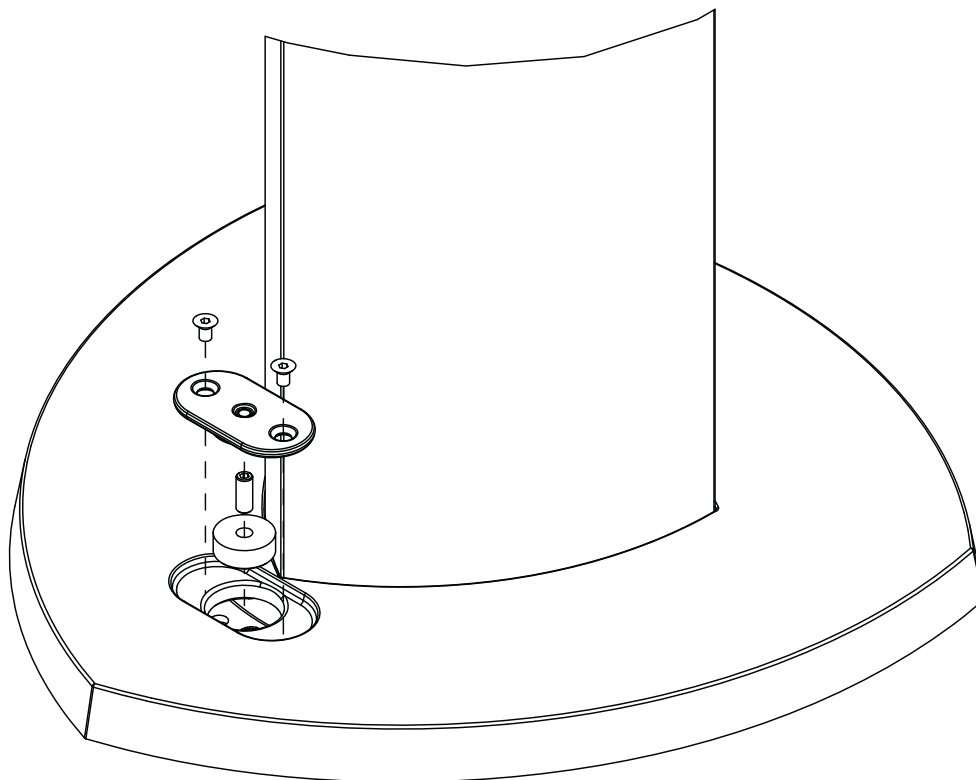

Jøtul F 273 / F 363 / F 373 / F 473



Jøtul F 273 / F 363 / F 373 / F 473

Steel Chimney
Max 150 kg

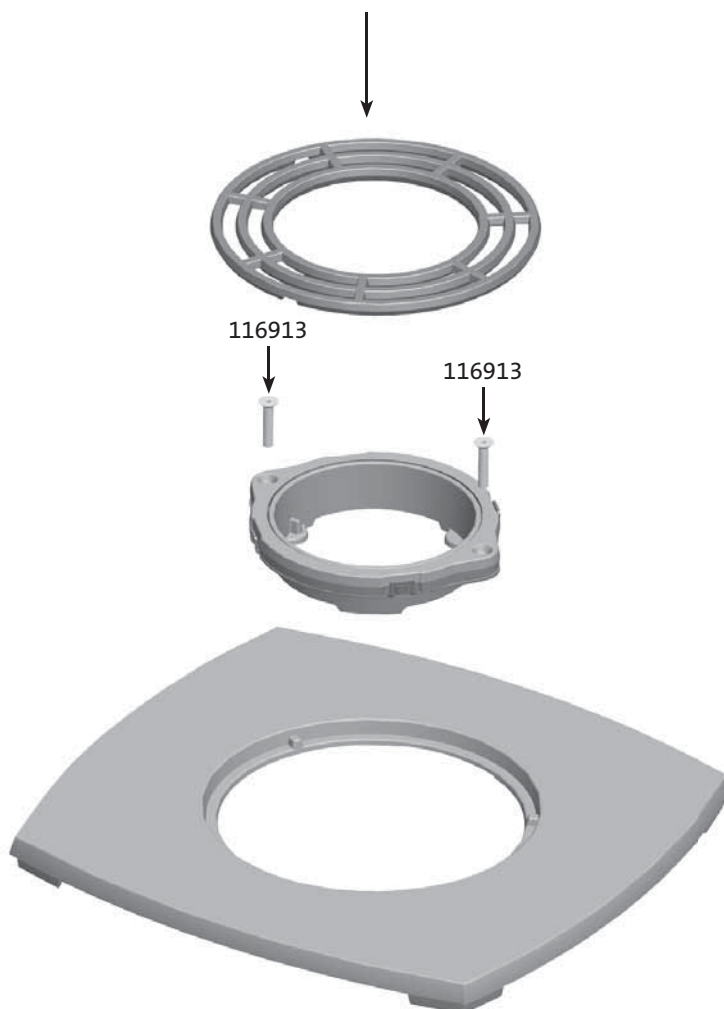

Jøtul F 273 / F 363 / F 373 / F 473

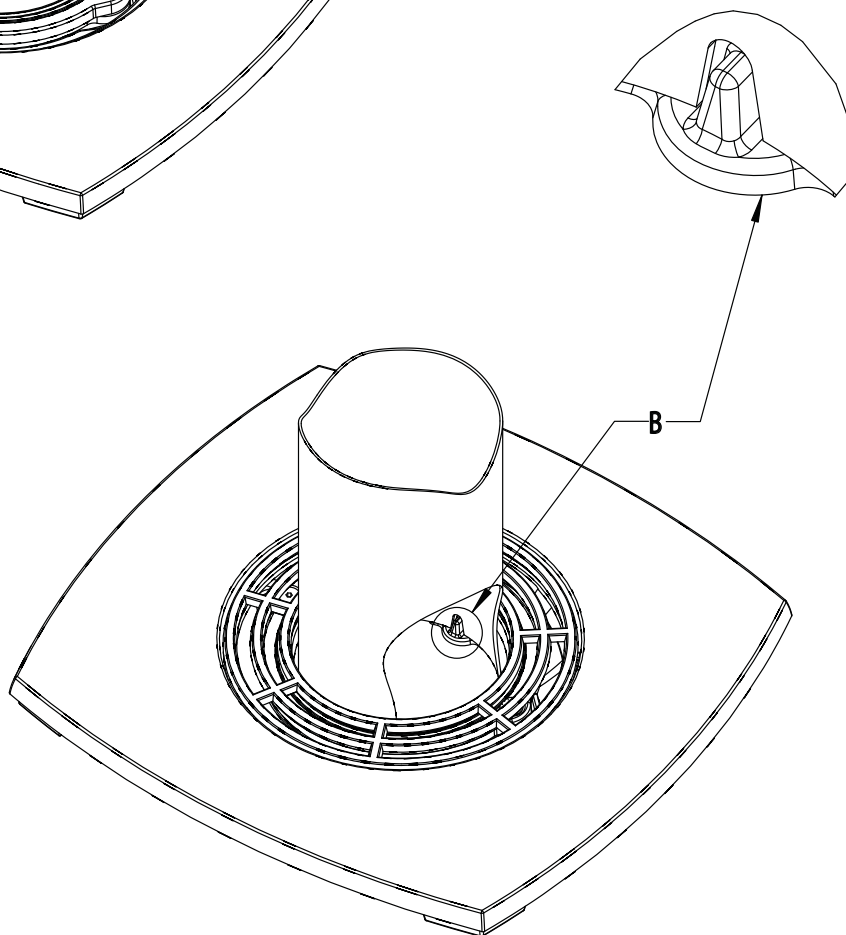
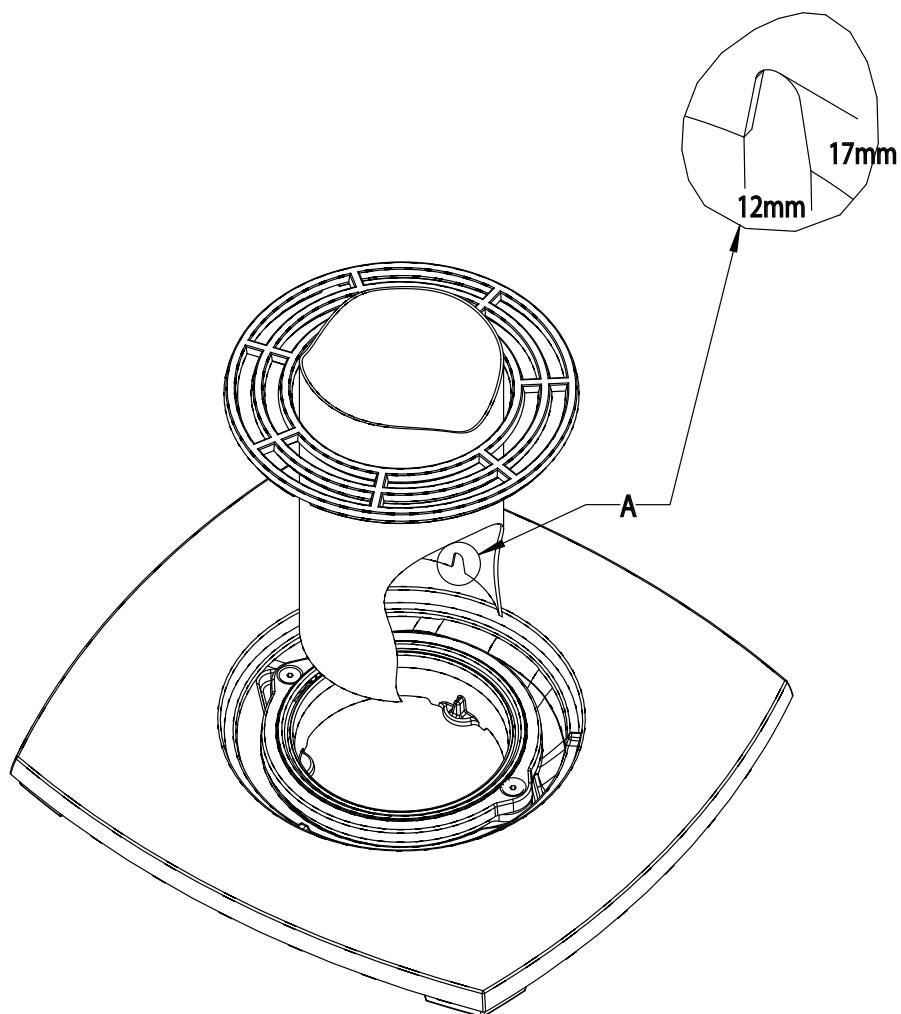

Cat.no. 221869-Pos
Jøtul AS, Nov. 2010

Jøtul arbeider kontinuerlig for om mulig å forbedre sine produkter, og vi forbeholder oss retten til å endre spesifikasjoner, farger og utstyr uten nærmere kunngjøring.

Jøtul bemüht sich ständig um die Verbesserung seiner Produkte, deshalb können Spezifikationen, Farben und Zubehör von den Abbildungen und den Beschreibungen in der Broschüre abweichen.

Jøtul pursue a policy of constant product development. Products supplied may therefore differ in specification, colour and type of accessories from those illustrated and described in the brochure.

Jøtul vise sans cesse à améliorer ses produits. C'est pourquoi, il se réserve le droit de modifier les specifications, couleurs et équipements sans avis préalable.

Kvalitet

Jøtul AS arbeider etter et kvalitetssikringssystem basert på NS-EN ISO 9001 for utvikling, produksjon og salg av ildsteder. Vår kvalitetspolitikk skal gi kundene den trygghet og kvalitetsopplevelse som Jøtul har stått for siden bedriftens historie startet i 1853.

Qualität

Jøtul AS hat ein Qualitätssicherungssystem, das sich bei Entwicklung, Produktion und Verkauf von Öfen und Kaminen nach NS-EN ISO 9001 richtet. Diese Qualitätspolitik vermittelt unseren Kunden ein Gefühl von Sicherheit und Qualität, für das Jøtul mit seiner langjährigen Erfahrung seit der Firmengründung im Jahre 1853 steht.

Quality

Jøtul AS has a quality system that conforms to NS-EN ISO 9001 for product development, manufacturing, and distribution of stoves and fireplaces. This policy gives our customers quality and safety piece of mind as a result of Jøtul's vast experience dating back to when the company first started in 1853.

Qualité

Le système de contrôle de la qualité de Jøtul AS est conforme à la norme NS-EN ISO 9001 relative à la conception, à la fabrication et à la distribution de poêles, foyers et inserts. Cette politique nous permet d'offrir à nos clients une qualité et une sécurité reposant sur la vaste expérience accumulée par Jøtul depuis sa création en 1853.



Jøtul AS,
P.O. box 1411
N-1602 Fredrikstad,
Norway